The Anticounter System of the PAMELA Space Experiment

M. Pearce,¹ P. Carlson,¹ J. Lund,¹ J. Lundquist,¹ S. Orsi¹ and S. Rydström¹
(1) *Dept. of Physics, The Royal Institute of Technology, Stockholm, Sweden.*

Abstract

The PAMELA space experiment [4] will be launched on-board of a polar-orbiting Resurs DK1 satellite in 2004. The primary objective of PAMELA is to measure the flux of antiprotons (80 MeV - 190 GeV) and positrons (50 MeV - 270 GeV) in the cosmic radiation. PAMELA is built around a permanent magnet silicon spectrometer which is surrounded by an anticounter system. The anticounter system uses sheets of plastic scintillator to identify particles which do not pass cleanly through the acceptance of the spectrometer but still give rise to coincidental energy deposits in the time-of-flight / trigger scintillators positioned at the entrance and exit of the spectrometer. The construction of the anticounter system is described in detail along with the custom read-out, data acquisition and calibration electronics. Results from qualification studies are also discussed.

1. Introduction

Four lateral anticounter detectors cover the sides and top of the PAMELA tracker, as shown in figure 1. The anticounter system is designed to help reject particles which do not pass cleanly through the tracking system but still give rise to coincident energy deposits in the three time-of-flight scintillators. This scenario is illustrated in figure 1. The anticounters form part of the PAMELA second level trigger [2].

2. Detector Construction

Each detector is constructed from a piece of 8 mm thick Bicron BC-448M plastic scintillator. This is a modified version of the standard BC-408 product with a cross-linked structure for improved temperature stability. The scintillators are wrapped first in two layers of reflective Dupont Tyvek and then an opaque layer of Dupont Tedlar. The scintillator is coupled to Hamamatsu R5900U photomultiplier tubes (PMT), operating at 800 V. The PMTs have a window thickness of 0.8 mm and are coupled to the scintillator with 7 mm thick silicone pads. Encapsulated high voltage divider boards are mounted directly behind the PMTs. The scintillator/PMT assembly is held inside a 1.5 mm thick aluminium frame which

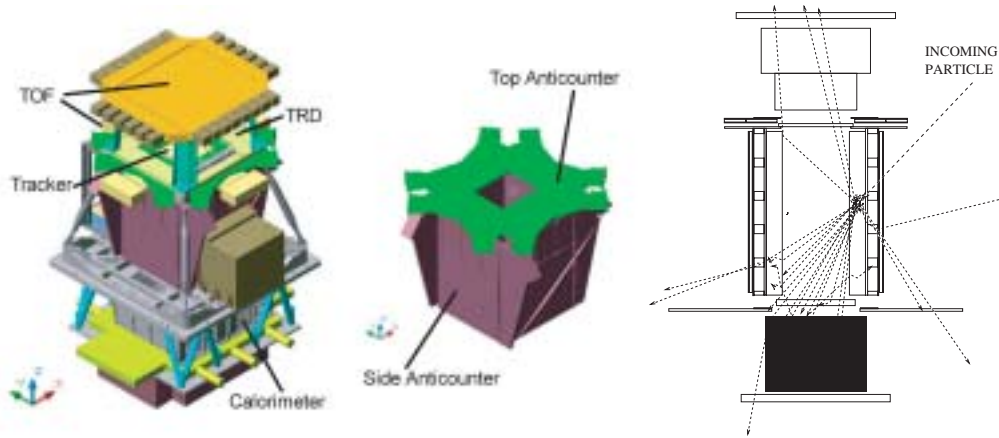

Fig. 1. Left: a stylised view of the PAMELA experiment showing the location of the anticounter system. PAMELA is approximately 1.2 m tall. Right: a simulation of a false trigger. A proton enters PAMELA from the side and interacts in the magnet producing secondaries which give coincidental energy deposits in the time-of-flight scintillators thereby producing a trigger.

maintains a consistent optical contact within the PMT/silicone pad/scintillator sandwich and allows the anticounter to be securely fixed to the PAMELA superstructure. In order to decrease the chance of a single point failure, each side anticounter and top anticounter quadrant is read out using two identical PMTs, so there are 16 PMTs in total. A miniature low intensity light emitting diode (LED) operating at 640 nm is glued directly onto the lower part of the side anticounter scintillator and two LEDs are glued to opposite sides of the top anticounter scintillator. The LEDs allow the functionality and stability of the anticounters to be verified in-flight. The PAMELA magnet is well shielded with ferromagnetic screens. This is primarily to avoid conflicts with the magnetic steering system of the satellite. The fringe field at the position of the anticounters is small enough that additional PMT shielding is not required. The total mass of the detectors, including cables is 2.9 kg (5.8 kg) per side (top) anticounter.

3. Front-end Electronics and Read-out System

Signals from the 16 PMTs are fed to a single 6U-sized electronic board. This board houses both the analog front-end and read-out system. The average power consumption is 2.5 W. The analogue front-end includes a combined integration/amplification stage and a discriminator based around the AD8500 and AD8651 chips, respectively. Discrimination voltages are provided with 8-bit AD5300 digital-to-analogue converter chips. The discriminated pulses are fed into a 32-bit shift register implemented in an Actel A54SX72A gate array clocked at 25 MHz. The PAMELA trigger is used to gate the shift register clock. Anti-

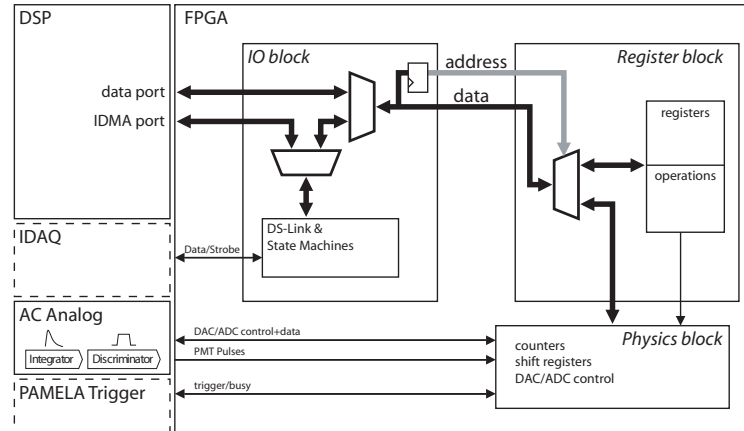

Fig. 2. A schematic overview of the anticounter electronics system. The calibration and housekeeping systems are not shown.

counter pulses which are in time with the trigger appear in the centre of the shift register. The shift register therefore provides relative timing information. Pulse height information is not recorded.

The gate array performs all tasks for the default physics operation mode. As well as providing the shift registers contents, singles and coincidence scalars are updated, board temperatures are monitored and error checks are performed. Communication with the PAMELA data acquisition system ('IDAQ'), housekeeping and trigger systems is realised through redundant LVDS data links using the data-strobe protocol. The gate array is interfaced to a Digital Signal Processor (ADSP-2187) which provides the additional functionality needed for the LED calibration system. A calibration consists of sending a predetermined number of 25 ns long pulses to the LEDs. Each pulse approximates the energy deposition from a minimum ionising particle. The number of resulting discriminated pulses at a selection of different discrimination voltages is recorded. A central theme of the electronics design is to reduce the possibility of single point failures. For example, each electronics channel is independent apart from sharing (redundant) power buses. The power buses are protected with fast FET current clamps to protect against single event latch-up. Through-out the electronics system, 'off the shelf' industrial grade components have been used and tested for resistance to ionising radiation.

4. Qualification Tests

The anticounter system has been subjected to a number of tests to validate the design approach, confirm detector performance and study the use of the anticounters to reject false triggers. A study of the light collection uniformity and

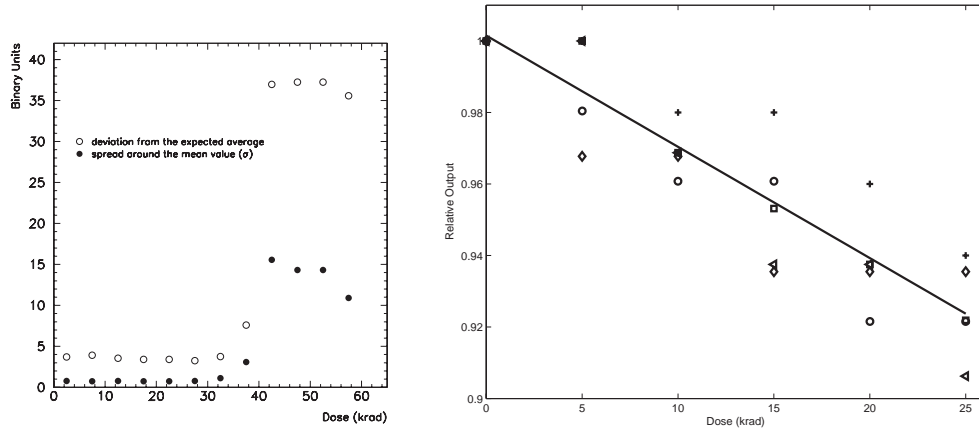

Fig. 3. Left: The effect of ionising radiation on the expected ADC output. At a dose 6 times higher than expected during the PAMELA mission (30 krad) the ADC chip malfunctions. Right: The output intensity of a selection of LEDs tested for the anticounter calibration system. An attenuation of approximately 10 % is seen after 30 krad.

tests with particle beams are described elsewhere in these proceedings [1]. One of the most important detector qualification tests was to determine the response of the system (and in particular the PMTs) to the random vibrations expected during launch. This is reported upon extensively elsewhere [3].

During PAMELA's 3 year mission components will receive an estimated total ionising dose of approximately 5 krad. Since the electronics system is built entirely from 'off-the-shelf' components, an extensive testing program has been followed to qualify each component used with a ^{60}Co source. As an example of these studies, figure 3 shows radiation tolerance studies of an AD7827 analog to digital converter chip used in the temperature monitoring system. Also shown is the effect of radiation on the calibration LED.

5. References

1. J. Lund et al., these proceedings.
2. J. Lundquist et al., these proceedings.
3. M. Pearce et al., Nucl. Instr. and Meth. A 488 (2002) 536.
4. M. Pearce, Nucl. Phys. B 113 (2002) 314.